

Loyalty Credits

For each consecutive year you are enrolled in our **Platinum or Gold Agreement**, you earn **\$50** in Loyalty Credits. You can accumulate up to **\$500** in credits and apply them to the following equipment purchased from us.*

- ❖ *heat pump* \$400
- ❖ *boiler* \$350
- ❖ *furnace* \$250
- ❖ *central a/c system* \$250
- ❖ *oil tank* \$200
- ❖ *oil water heater* \$200
- ❖ *burner* \$100

*A maximum of \$50 in Loyalty Credits are awarded each year, regardless of how many Energy Savings Agreements you have.

Guarantees for dependable service

- We guarantee you **priority emergency heating service**, 24 hours a day, 7 days a week, including weekends and holidays.
- If you lose your heating or cooling, we'll be at your home the **same day you call**.
- The first and last appointments of the day are reserved exclusively for service plan customers scheduling maintenance.
- All parts replaced by Dowling are covered by a two-year warranty, as long as your Energy Savings Agreement remains in effect. If a part needs to be replaced before the warranty expires, you pay nothing for the repair.
- We stock our vehicles with thousands of dollars' worth of parts so we can **fix most problems in one visit** to your home.
- We always use **new parts for repairs**; only professional testing equipment, not guesswork, is used to evaluate your system.
- Only our **expert technicians** do repairs on your system. Plus, they will always leave your home as clean as they found it.

If we don't live up to any of these guarantees, we'll credit your account \$50!

DowlingTM
Dependability • Integrity

100 Industrial Ave.
Ridgefield Park, NJ 07660

201-440-1000
DowlingHVAC.com



7953-11227



Energy Savings Agreement

Depend on service and savings!

Security and Savings You Can Count On

Our **Energy Savings Agreement** has been designed to help you get the most from your energy dollars and give you confidence that you have the best home comfort protection—because the last thing you need is a big unexpected repair bill or an inefficient heating or cooling system.

When you're protected by an Energy Savings Agreement, you have a lot less to worry about. We can take away your worries and make your comfort easy, whether you heat your home with oil or gas, or cool your home with a central air conditioning system or a heat pump. We cover them all.

We give you options.

We offer two plan levels, both of which include a tune-up and many more benefits. This will save you money, reduce inconvenience and extend the life of your home comfort equipment.

Our **Gold Agreement** provides a tune-up, discounts on repairs and guaranteed emergency heating service, 24 hours a day. If you have no heat, we'll be at your home the same day you call.

For a few more dollars a month, you can get our **Platinum Agreement**, which includes everything in the Gold Agreement and more—completely **FREE** repairs on covered items.



Chris, Ernest and Drew Behrens

Whether you select the Gold Agreement or the Platinum Agreement, you'll be secure knowing you're protected and that we are ready and able to take the best care of your family.

Sincerely,

Chris E Behrens
Ernest K Behrens
Drew J Behrens

Chris, Ernest and Drew Behrens

A customer's story

"Your service agreement has helped me keep my equipment in good shape. I never have to worry about it. And on the few occasions when I needed emergency service, your team was here promptly and solved the problem."

— Joan Majeune, Englewood

Questions you may have:

Q: Why should I invest in an Energy Savings Agreement?

A: For peace of mind, comfort and savings. Our Energy Savings Agreement includes an annual tune-up, repair savings and a guaranteed fast response if you should need service.

Q: Why are tune-ups important?

A: A tune-up can save you hundreds of dollars on heating and cooling costs by improving system efficiency. Tune-ups also prevent many breakdowns and extend the life of your equipment.



Q: How do I save on repairs?

A: Depending on the kind of system you have, the cost—without an Energy Savings Agreement—of a new blower motor for a furnace is \$450; for a new control for a boiler the cost is \$350. If you have our Gold Agreement, you'll save 15% on these costs. Better yet, the Platinum Agreement picks up 100% of the cost for replacing these parts—and dozens of others.

Q: Which plan is best for me?

A: Your choice of our Gold Agreement or Platinum Agreement depends on the level of protection you're comfortable with. You may be able to save the most with our comprehensive Platinum Agreement because

most repairs are fully covered. However, the Gold Agreement, which includes repair discounts and a tune-up, can also serve you well, especially if your equipment is five years old or less.

Q: What coverage can I get?

A: We offer coverage for oil and gas heating systems, central air systems, heat pump and oil-fired water heaters. We also offer a separate oil tank protection plan called ProGuard.

Q: How do I get started?

A: Call us or return the enclosed card. You can also ask your technician to sign you up for a plan when he is at your home on his next service visit.

How much you save

	Platinum Agreement	Gold Agreement
blower motor	\$450	\$68
control	\$350	\$53
contactor	\$200	\$30

UNDERSTANDING your system

boiler

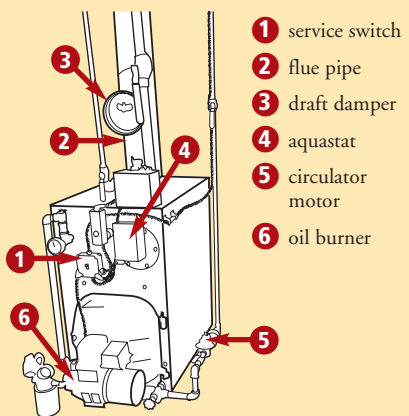

oil furnace

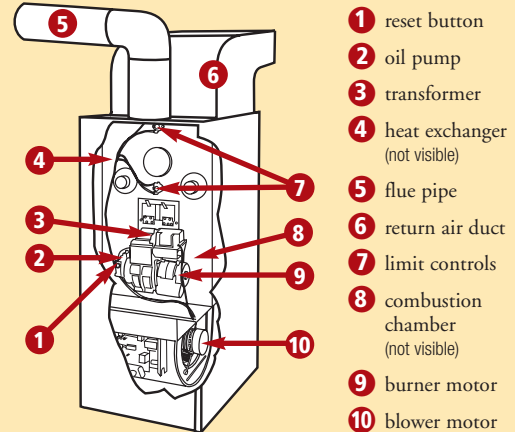

gas furnace

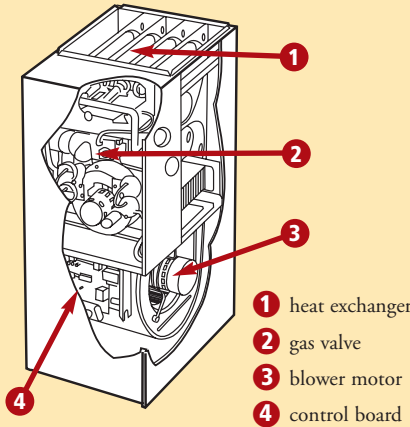

central air/heat pump

